

PSP C series



PROSURGE® PSP C series panel SPDs are defined as high performance surge protection solution for most commercial and industrial environments with critical operations. They include Type 1 and Type 2 Surge Protective Devices (SPDs) that protect against the harmful effects of transient surges. These surges are the result of:

- Direct and indirect lightning strikes
- Power company load switching
- Upstream load switching at other facilities

The SPD Types Per ANSI / UL 1449 4th:

**Type 1** – Permanently connected SPDs intended for installation between the secondary of the service transformer and the line side of the service equipment overcurrent device, as well as the load side, including watt-hour meter socket enclosures and Molded Case SPDs intended to be installed without an external overcurrent protective device.

**Type 2** – Permanently connected SPDs intended for installation on the load side of the service equipment overcurrent device; including SPDs located at the branch panel and Molded Case SPDs.

PSP C is constructed with Prosurge’s patented PTMOVs, which has a thermally protected and arc extinguishing technology as the core of Prosurge’s competency. PSP C has a significant advantage in abnormal over-voltage & high fault current safety and thus ensures industry’s highest level of safety and performance. The parallel redundancy modules design makes the SPDs extremely robust and reliable and thus may handle great impulse current up to 300kA (8/20 μs) and multiple impulse current at its highest rated level.

The Prosurge PSP C series are tested and listed as UL1449 4th Type 1 and Type 2 SPD (with sine wave tracking function). Their front panels integrate functionality of SPD working status monitor and self-diagnosis to enhance the performance and usability. They feature with indicator and colored LEDs to demonstrate the power & protection status of each protected power phase. They are constructed with NEMA 4/4X enclosures to ensure that dirt, dust and water are resisted for either indoor or outdoor usage.

**Outstanding PTMOV Technology**



*Thermally Protected MOV technology. Fast and safely disconnect in the case of abnormal over-voltage or current fault conditions.*

■ **Typical Applications:**

In high & medium exposure locations

- Commercial
- Industrial
- Communications
- Renewable energy
- Critical power (hospitals, data centers, etc)

■ **Features:**

- UL 1449 4<sup>th</sup> Type 1 SPDs with SCCR up to 200kArms without external fuse or CB
- UL1449 4<sup>th</sup> Type 2 SPDs with Sine Wave Tracking, SCCR 200kArms
- Prosurge Patented SCCR 200kArms thermally protected MOV technology(PTMOV) as core component
- Full modes protection
- High surge energy capability with compact size
- Low voltage protection rating
- Degradation failure indication.
- Surge event counter optional
- Sine wave tracking function optional (for UL Type 2 listed)
- Two type enclosure, NEMA 4X plastic and NEMA 4 metal enclosure to resist dirt, dust and water
- Audible alarm, beep while SPD fail
- Remote Alarm optional
- Threaded NPT

■ **Configure & Ordering Information:**

<u>PSP</u> Model series	<u>277Y</u> Voltage and system configuration	<u>C</u> Protection mode	<u>42</u> Surge capacity	<u>M</u> Enclosure	<u>/ T1</u> SPD Category	<u>CTA</u> Additional function
<u>PSP</u>	<u>120SP</u> : 120/240V split <u>240SP</u> :240/480V split <u>120Y</u> :120/1208V WYE <u>277Y</u> : 277/480V WYE <u>120H</u> : 120/240V high leg delta <u>240D</u> : 240V delta <u>120S</u> :120V 1ph, 2W+G ...	<u>C</u> : Delete N-G protection mode	<u>11</u> : 25kA per phase <u>12</u> :50kA per phase <u>22</u> :100kA per phase <u>32</u> :150kA per phase <u>42</u> :200kA per phase <u>52</u> :250kA per phase <u>62</u> :300kA per phase	<u>M</u> : metal enclosure (Only C2 type) *Part No. without <u>M</u> means plastic enclosure (C1 type)	<u>T1</u> : UL type 1 SPD <u>T2F</u> : UL type 2 SPD with sine wave tracking	<u>C</u> : surge event counter

**1. Voltage code for power distribution system**

- 120SP ,240SP= 120/240V;240/480V-----Split-phase three-wire + ground (Figure1)
- 120Y, 127Y, 240Y, 277Y, 347Y = 208Y/120V,220Y/127V, 415Y/240V, 480Y/277V, 600Y/347V-----Three-phase wye (star) four-wire + ground (Figure2)
- 120H, 240H = 120/240V, 240V/480V-----Three-phase high leg delta (Figure3)
- 240D, 480D, 600D = 240V, 480V, 600V-----Three-phase delta three-wire + ground (Figure4)
- 120S, 127S, 240S, 277S, 347S =120V, 127V, 240V, 277V, 347V-----single-phase two-wire + ground (Figure5)

One-port Panel SPDs

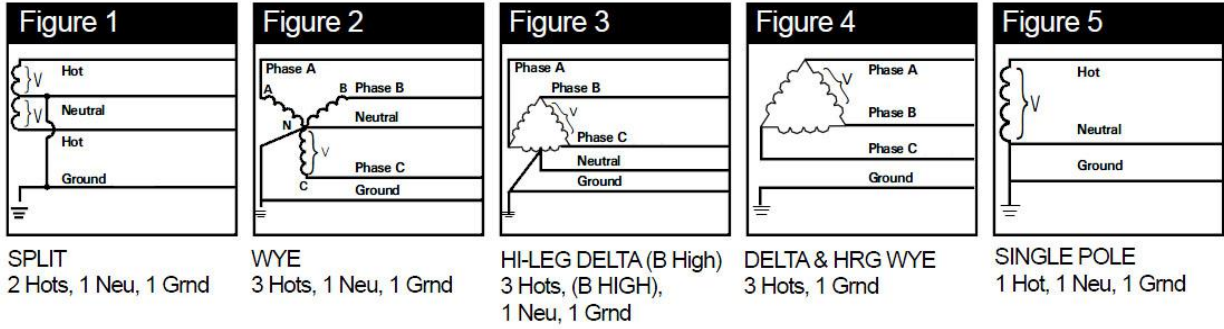

2.M: Metal enclosure (without "M": plastic enclosure)



PSP C1 (NEMA 4X plastic enclosure)



PSP C2 (NEMA 4 metal enclosure)

3. # SPD Type per UL1449 4th edition

- T1= UL Type 1 SPD
- T2F=UL Type 2 SPD with Sine wave tracking

4. # : Optional function

- C = Surge Counter
- T=Failure Test
- A=Remote Alarm



Basic circuit diagram

Note: x means 1 to 6 (Surge capacity 50kA~300kA)

Un/ Power system (50/60 HZ)	Basic circuit diagram of surge protection circuit	
	Power System has Neutral Line	Power System has No Neutral Line
120/240 VAC Split phase 240/480 VAC Split phase ...	PSP... <b>SPx2</b> ...(3W+G) 	PSP... <b>SPCx2</b> ...(2W+G) 
120 VAC single phase 127 VAC single phase 220 VAC single phase 230 VAC single phase 240 VAC single phase 277 VAC single phase 347 VAC single phase ...	PSP... <b>Sx2</b> ...(2W+G) 	
120/208 VAC WYE 127/220 VAC WYE 220/380 VAC WYE 230/400 VAC WYE 240/415VAC WYE 277/480 VAC WYE 347/600 VAC WYE ...	PSP... <b>Yx2</b> ...(4W+G) 	PSP... <b>YCx2</b> ...(3W+G) 
240 VAC Delta 480 VAC Delta 600 VAC Delta ...		PSP... <b>Dx2</b> ...(3W+G) 
120/240 VAC Hi-leg delta 240/480 VAC Hi-leg delta ...	PSP... <b>Hx2</b> ...( 4W+G, L2 is High leg) 	PSP... <b>HCx2</b> ...(3W+G, L2 is High leg) 

■ Dimensions (unit: mm)

PSP series can be fixed with bolts. The dimension of the devices and bolt holes as below diagrams.

■ Typical for PSP C1 series

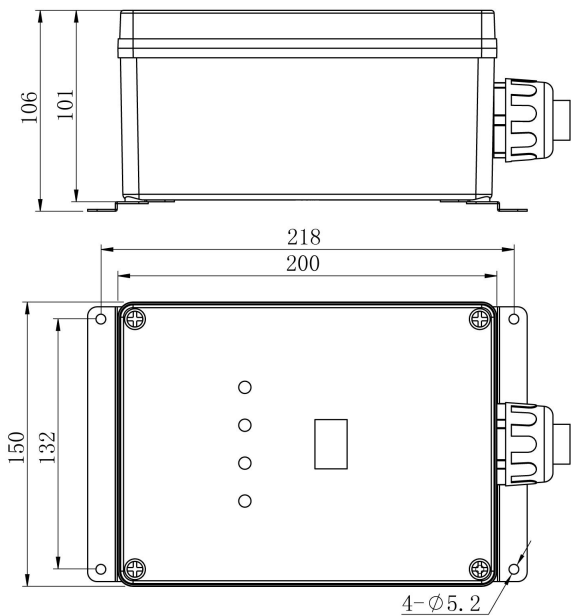

■ Typical for PSP C2 series

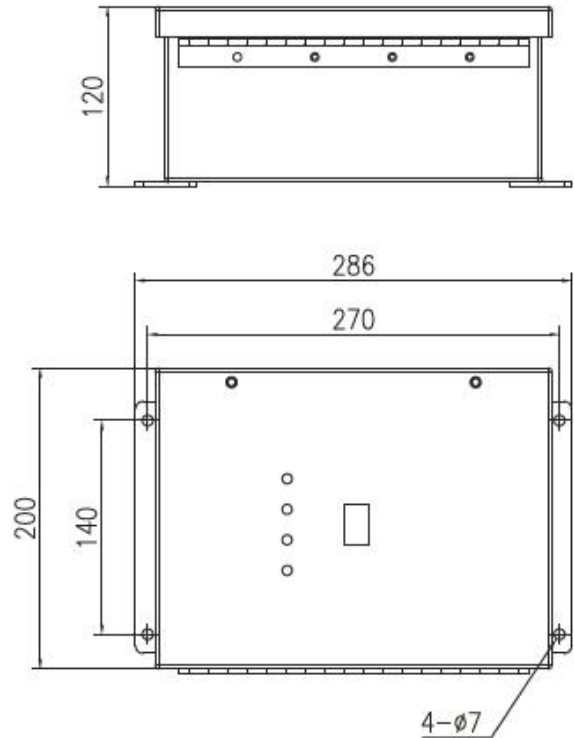

■ General Specification:

PSP category	C1	C2
Certification	ANSI/UL1449 4 <sup>th</sup> edition, Type1/ 2	
Connection Type	Parallel Connected	
Surge Capacity	100-300kA per Phase	
SCCR	200kArms	
Sine wave tracking	Optional for UL Type 2 listed	
Lightning counter Current	≥ 200A (with Reset button )	
Failure pre-test	Press 2S (test button)	
Power Status Indication	Normal=Blue LED ON	
Working Status Indication	Normal= Blue LED ON; Fail= Blue LED turn to Red Buzzer inside, beep while SPD fail	
Power Connecting	10AWG, 762mm (30") length, (L1=black; L2=red; L3=blue; N=white; PE=green )	
Signal cable	16AWG, 762mm (30") length,(C=red; NC=blue; NO=brown)	
Working environments	Temperature -40℃ ~+75℃, Humidity relative 5~95% (25℃) , Altitudes≤3km	
Dimensions (W x D x H)	200 x 150 x 100 mm	286 x 200 x 120 mm
Threaded NPT	3/4"NPT	
Enclosure	Plastic enclosure, NEMA 4X	Metal enclosure, NEMA 4
Net Weight (typical value)	1.59 kg	4.3 kg

One-port Panel SPDs

■ Technical Data:

Model No.	System voltage (50/60Hz)	In (kA)	Protected mode				Voltage Protection Ratings (VPR @6kV/ 3kA)				Surge Capability	MCOV (Vac)
			L-N	L-G	N-G	L-L	L-N	L-G	N-G	L-L		
PSP120SP22/*#	120/240V split-phase	20	✓	✓	✓	✓	700	800	800	1200	100kA/phase, 50kA/mode	150/300*
PSP120SP32/*#			✓	✓	✓	✓	700	800	800	1200	150kA/phase, 75kA/mode	150/300*
PSP120SP42/*#			✓	✓	✓	✓	700	800	800	1200	200kA/phase, 100kA/mode	150/300*
PSP120SP52/*#			✓	✓	✓	✓	700	800	800	1200	250kA/phase, 125kA/mode	150/300*
PSP120SP62/*#			✓	✓	✓	✓	700	800	800	1200	300kA/phase, 150kA/mode	150/300*
PSP120SPC22/*#	120/240V split-phase No neutral	20	✗	✓	✗	✓	-	800	-	1200	100kA/phase, 50kA/mode	150/300*
PSP120SPC32/*#			✗	✓	✗	✓	-	800	-	1200	150kA/phase, 75kA/mode	150/300*
PSP120SPC42/*#			✗	✓	✗	✓	-	800	-	1200	200kA/phase, 100kA/mode	150/300*
PSP120SPC52/*#			✗	✓	✗	✓	-	800	-	1200	250kA/phase, 125kA/mode	150/300*
PSP120SPC62/*#			✗	✓	✗	✓	-	800	-	1200	300kA/phase, 150kA/mode	150/300*
PSP240SP22/*#	240/480V split-phase	20	✓	✓	✓	✓	1200	1200	1200	2000	100kA/phase, 50kA/mode	320/640*
PSP240SP32/*#			✓	✓	✓	✓	1200	1200	1200	2000	150kA/phase, 75kA/mode	320/640*
PSP240SP42/*#			✓	✓	✓	✓	1200	1200	1200	2000	200kA/phase, 100kA/mode	320/640*
PSP240SP52/*#			✓	✓	✓	✓	1200	1200	1200	2000	250kA/phase, 125kA/mode	320/640*
PSP240SP62/*#			✓	✓	✓	✓	1200	1200	1200	2000	300kA/phase, 150kA/mode	320/640*
PSP240SPC22/*#	240/480V split-phase No neutral	20	✗	✓	✗	✓	-	1200	-	2000	100kA/phase, 50kA/mode	320/640*
PSP240SPC32/*#			✗	✓	✗	✓	-	1200	-	2000	150kA/phase, 75kA/mode	320/640*
PSP240SPC42/*#			✗	✓	✗	✓	-	1200	-	2000	200kA/phase, 100kA/mode	320/640*
PSP240SPC52/*#			✗	✓	✗	✓	-	1200	-	2000	250kA/phase, 125kA/mode	320/640*
PSP240SPC62/*#			✗	✓	✗	✓	-	1200	-	2000	300kA/phase, 150kA/mode	320/640*

One-port Panel SPDs

PSP127Y22/*#	220Y127V Three-phase wye	20	✓	✓	✓	✓	700	800	800	1200	100kA/phase, 50kA/mode	150
PSP127Y32/*#			✓	✓	✓	✓	700	800	800	1200	150kA/phase, 75kA/mode	150
PSP127Y42/*#			✓	✓	✓	✓	700	800	800	1200	200kA/phase, 100kA/mode	150
PSP127Y52/*#			✓	✓	✓	✓	700	800	800	1200	250kA/phase, 125kA/mode	150
PSP127Y62/*#			✓	✓	✓	✓	700	800	800	1200	300kA/phase, 150kA/mode	150
PSP127YC22/*#	220Y127V Three-phase wye No neutral	20	x	✓	x	✓	-	800	-	1200	100kA/phase, 50kA/mode	150
PSP127YC32/*#			x	✓	x	✓	-	800	-	1200	150kA/phase, 75kA/mode	150
PSP127YC42/*#			x	✓	x	✓	-	800	-	1200	200kA/phase, 100kA/mode	150
PSP127YC52/*#			x	✓	x	✓	-	800	-	1200	250kA/phase, 125kA/mode	150
PSP127YC62/*#			x	✓	x	✓	-	800	-	1200	300kA/phase, 150kA/mode	150
PSP120Y22/*#	208Y120V Three-phase wye	20	✓	✓	✓	✓	700	800	800	1200	100kA/phase, 50kA/mode	150
PSP120Y32/*#			✓	✓	✓	✓	700	800	800	1200	150kA/phase, 75kA/mode	150
PSP120Y42/*#			✓	✓	✓	✓	700	800	800	1200	200kA/phase, 100kA/mode	150
PSP120Y52/*#			✓	✓	✓	✓	700	800	800	1200	250kA/phase, 125kA/mode	150
PSP120Y62/*#			✓	✓	✓	✓	700	800	800	1200	300kA/phase, 150kA/mode	150
PSP120YC22/*#	208Y120V Three-phase wye No neutral	20	x	✓	x	✓	-	800	-	1200	100kA/phase, 50kA/mode	150
PSP120YC32/*#			x	✓	x	✓	-	800	-	1200	150kA/phase, 75kA/mode	150
PSP120YC42/*#			x	✓	x	✓	-	800	-	1200	200kA/phase, 100kA/mode	150
PSP120YC52/*#			x	✓	x	✓	-	800	-	1200	250kA/phase, 125kA/mode	150
PSP120YC62/*#			x	✓	x	✓	-	800	-	1200	300kA/phase, 150kA/mode	150

One-port Panel SPDs

PSP240Y22/*#	415Y/240V Three-phase wye	20	✓	✓	✓	✓	1200	1200	1200	2000	100kA/phase, 50kA/mode	320
PSP240Y32/*#			✓	✓	✓	✓	1200	1200	1200	2000	150kA/phase, 75kA/mode	320
PSP240Y42/*#			✓	✓	✓	✓	1200	1200	1200	2000	200kA/phase, 100kA/mode	320
PSP240Y52/*#			✓	✓	✓	✓	1200	1200	1200	2000	250kA/phase, 125kA/mode	320
PSP240Y62/*#			✓	✓	✓	✓	1200	1200	1200	2000	300kA/phase, 150kA/mode	320
PSP240YC22/*#	415Y/240V Three-phase wye No neutral	20	✗	✓	✗	✓	-	1200	-	2000	100kA/phase, 50kA/mode	320
PSP240YC32/*#			✗	✓	✗	✓	-	1200	-	2000	150kA/phase, 75kA/mode	320
PSP240YC42/*#			✗	✓	✗	✓	-	1200	-	2000	200kA/phase, 100kA/mode	320
PSP240YC52/*#			✗	✓	✗	✓	-	1200	-	2000	250kA/phase, 125kA/mode	320
PSP240YC62/*#			✗	✓	✗	✓	-	1200	-	2000	300kA/phase, 150kA/mode	320
PSP277Y22/*#	480Y/277V Three-phase wye	20	✓	✓	✓	✓	1200	1200	1200	2000	100kA/phase, 50kA/mode	320
PSP277Y32/*#			✓	✓	✓	✓	1200	1200	1200	2000	150kA/phase, 75kA/mode	320
PSP277Y42/*#			✓	✓	✓	✓	1200	1200	1200	2000	200kA/phase, 100kA/mode	320
PSP277Y52/*#			✓	✓	✓	✓	1200	1200	1200	2000	250kA/phase, 125kA/mode	320
PSP277Y62/*#			✓	✓	✓	✓	1200	1200	1200	2000	300kA/phase, 150kA/mode	320
PSP277YC22/*#	480Y/277V Three-phase wye No neutral	20	✗	✓	✗	✓	-	1200	-	2000	100kA/phase, 50kA/mode	320
PSP277YC32/*#			✗	✓	✗	✓	-	1200	-	2000	150kA/phase, 75kA/mode	320
PSP277YC42/*#			✗	✓	✗	✓	-	1200	-	2000	200kA/phase, 100kA/mode	320
PSP277YC52/*#			✗	✓	✗	✓	-	1200	-	2000	250kA/phase, 125kA/mode	320
PSP277YC62/*#			✗	✓	✗	✓	-	1200	-	2000	300kA/phase, 150kA/mode	320



One-port Panel SPDs

PSP347Y22/*#	600Y347V Three-phase wye	20	✓	✓	✓	✓	1500	1500	1500	2500	100kA/phase, 50kA/mode	420
PSP347Y32/*#			✓	✓	✓	✓	1500	1500	1500	2500	150kA/phase, 75kA/mode	420
PSP347Y42/*#			✓	✓	✓	✓	1500	1500	1500	2500	200kA/phase, 100kA/mode	420
PSP347Y52/*#			✓	✓	✓	✓	1500	1500	1500	2500	250kA/phase, 125kA/mode	420
PSP347Y62/*#			✓	✓	✓	✓	1500	1500	1500	2500	300kA/phase, 150kA/mode	420
PSP347YC22/*#	600Y347V Three-phase wye No neutral	20	✗	✓	✗	✓	-	1500	-	2500	100kA/phase, 50kA/mode	420
PSP347YC32/*#			✗	✓	✗	✓	-	1500	-	2500	150kA/phase, 75kA/mode	420
PSP347YC42/*#			✗	✓	✗	✓	-	1500	-	2500	200kA/phase, 100kA/mode	420
PSP347YC52/*#			✗	✓	✗	✓	-	1500	-	2500	250kA/phase, 125kA/mode	420
PSP347YC62/*#			✗	✓	✗	✓	-	1500	-	2500	300kA/phase, 150kA/mode	420
PSP120H22/*#	120/240V high leg delta	20	✓	✓	✓	✓	700- 1200HL	800- 1200HL	800	1200-200 0HL	100kA/phase, 50kA/mode	150/ 320(HL)
PSP120H32/*#			✓	✓	✓	✓	700- 1200HL	800- 1200HL	800	1200- 2000HL	150kA/phase, 75kA/mode	150/ 320(HL)
PSP120H42/*#			✓	✓	✓	✓	700- 1200HL	800- 1200HL	800	1200- 2000HL	200kA/phase, 100kA/mode	150/ 320(HL)
PSP120H52/*#			✓	✓	✓	✓	700- 1200HL	800- 1200HL	800	1200- 2000HL	250kA/phase, 125kA/mode	150/ 320(HL)
PSP120H62/*#			✓	✓	✓	✓	700- 1200HL	800- 1200HL	800	1200-200 0HL	300kA/phase, 150kA/mode	150/ 320(HL)
PSP120HC22/*#	120/240V high leg delta No neutral	20	✗	✓	✗	✓	-	800- 1200HL	-	1200- 2000HL	100kA/phase, 50kA/mode	150/ 320(HL)
PSP120HC32/*#			✗	✓	✗	✓	-	800- 1200HL	-	1200- 2000HL	150kA/phase, 75kA/mode	150/ 320(HL)
PSP120HC42/*#			✗	✓	✗	✓	-	800- 1200HL	-	1200- 2000HL	200kA/phase, 100kA/mode	150/ 320(HL)
PSP120HC52/*#			✗	✓	✗	✓	-	800- 1200HL	-	1200- 2000HL	250kA/phase, 125kA/mode	150/ 320(HL)
PSP120HC62/*#			✗	✓	✗	✓	-	800- 1200HL	-	1200- 2000HL	300kA/phase, 150kA/mode	150/ 320(HL)

One-port Panel SPDs

PSP240H22/*#	240/480V high leg delta	20	✓	✓	✓	✓	1200- 1800HL	1200- 1800HL	1200	2000- 3000HL	100kA/phase, 50kA/mode	320/ 550(HL)
PSP240H32/*#			✓	✓	✓	✓	1200- 1800HL	1200- 1800HL	1200	2000- 3000HL	150kA/phase, 75kA/mode	320/ 550(HL)
PSP240H42/*#			✓	✓	✓	✓	1200- 1800HL	1200- 1800HL	1200	2000- 3000HL	200kA/phase, 100kA/mode	320/ 550(HL)
PSP240H52/*#			✓	✓	✓	✓	1200- 1800HL	1200- 1800HL	1200	2000- 3000HL	250kA/phase, 125kA/mode	320/ 550(HL)
PSP240H62/*#			✓	✓	✓	✓	1200- 1800HL	1200- 1800HL	1200	2000- 3000HL	300kA/phase, 150kA/mode	320/ 550(HL)
PSP240HC22/*#	240/480V high leg delta No neutral	20	✗	✓	✗	✓	-	1200- 1800HL	-	2000- 3000HL	100kA/phase, 50kA/mode	320/ 550(HL)
PSP240HC32/*#			✗	✓	✗	✓	-	1200- 1800HL	-	2000- 3000HL	150kA/phase, 75kA/mode	320/ 550(HL)
PSP240HC42/*#			✗	✓	✗	✓	-	1200- 1800HL	-	2000- 3000HL	200kA/phase, 100kA/mode	320/ 550(HL)
PSP240HC52/*#			✗	✓	✗	✓	-	1200- 1800HL	-	2000- 3000HL	250kA/phase, 125kA/mode	320/ 550(HL)
PSP240HC62/*#			✗	✓	✗	✓	-	1200- 1800HL	-	2000- 3000HL	300kA/phase, 150kA/mode	320/ 550(HL)
PSP240D22/*#	240V Three-phase delta	20	✗	✓	✗	✓	-	1200	-	1200	100kA/phase, 50kA/mode	320
PSP240D32/*#			✗	✓	✗	✓	-	1200	-	1200	150kA/phase, 75kA/mode	320
PSP240D42/*#			✗	✓	✗	✓	-	1200	-	1200	200kA/phase, 100kA/mode	320
PSP240D52/*#			✗	✓	✗	✓	-	1200	-	1200	250kA/phase, 125kA/mode	320
PSP240D62/*#			✗	✓	✗	✓	-	1200	-	1200	300kA/phase, 150kA/mode	320
PSP480D22/*#	480V Three-phase delta	20	✗	✓	✗	✓	-	1800	-	2000	100kA/phase, 50kA/mode	550
PSP480D32/*#			✗	✓	✗	✓	-	1800	-	2000	150kA/phase, 75kA/mode	550
PSP480D42/*#			✗	✓	✗	✓	-	1800	-	2000	200kA/phase, 100kA/mode	550
PSP480D52/*#			✗	✓	✗	✓	-	1800	-	2000	250kA/phase, 125kA/mode	550
PSP480D62/*#			✗	✓	✗	✓	-	1800	-	2000	300kA/phase, 150kA/mode	550

One-port Panel SPDs

PSP600D22/*#	600V Three-phase delta	20	x	✓	x	✓	-	2000	-	2500	100kA/phase, 50kA/mode	690
PSP600D32/*#			x	✓	x	✓	-	2000	-	2500	150kA/phase, 75kA/mode	690
PSP600D42/*#			x	✓	x	✓	-	2000	-	2500	200kA/phase, 100kA/mode	690
PSP600D52/*#			x	✓	x	✓	-	2000	-	2500	250kA/phase, 125kA/mode	690
PSP600D62/*#			x	✓	x	✓	-	2000	-	2500	300kA/phase, 150kA/mode	690
PSP120S22/*#	120V Single-phase	20	✓	✓	✓	x	700	800	800	-	100kA/phase, 50kA/mode	150
PSP120S32/*#			✓	✓	✓	x	700	800	800	-	150kA/phase, 75kA/mode	150
PSP120S42/*#			✓	✓	✓	x	700	800	800	-	200kA/phase, 100kA/mode	150
PSP120S52/*#			✓	✓	✓	x	700	800	800	-	250kA/phase, 125kA/mode	150
PSP120S62/*#			✓	✓	✓	x	700	800	800	-	300kA/phase, 150kA/mode	150
PSP127S22/*#	127V Single-phase	20	✓	✓	✓	x	700	800	800	-	100kA/phase, 50kA/mode	150
PSP127S32/*#			✓	✓	✓	x	700	800	800	-	150kA/phase, 75kA/mode	150
PSP127S42/*#			✓	✓	✓	x	700	800	800	-	200kA/phase, 100kA/mode	150
PSP127S52/*#			✓	✓	✓	x	700	800	800	-	250kA/phase, 125kA/mode	150
PSP127S62/*#			✓	✓	✓	x	700	800	800	-	300kA/phase, 150kA/mode	150
PSP240S22/*#	240V Single-phase	20	✓	✓	✓	x	1200	1200	1200	-	100kA/phase, 50kA/mode	320
PSP240S32/*#			✓	✓	✓	x	1200	1200	1200	-	150kA/phase, 75kA/mode	320
PSP240S42/*#			✓	✓	✓	x	1200	1200	1200	-	200kA/phase, 100kA/mode	320
PSP240S52/*#			✓	✓	✓	x	1200	1200	1200	-	250kA/phase, 125kA/mode	320
PSP240S62/*#			✓	✓	✓	x	1200	1200	1200	-	300kA/phase, 150kA/mode	320

One-port Panel SPDs

PSP277S22/*#	277V Single-phase	20	✓	✓	✓	*	1200	1200	1200	-	100kA/phase, 50kA/mode	320
PSP277S32/*#			✓	✓	✓	*	1200	1200	1200	-	150kA/phase, 75kA/mode	320
PSP277S42/*#			✓	✓	✓	*	1200	1200	1200	-	200kA/phase, 100kA/mode	320
PSP277S52/*#			✓	✓	✓	*	1200	1200	1200	-	250kA/phase, 125kA/mode	320
PSP277S62/*#			✓	✓	✓	*	1200	1200	1200	-	300kA/phase, 150kA/mode	320
PSP347S22/*#	347V Single-phase	20	✓	✓	✓	*	1500	1500	1500	-	100kA/phase, 50kA/mode	420
PSP347S32/*#			✓	✓	✓	*	1500	1500	1500	-	150kA/phase, 75kA/mode	420
PSP347S42/*#			✓	✓	✓	*	1500	1500	1500	-	200kA/phase, 100kA/mode	420
PSP347S52/*#			✓	✓	✓	*	1500	1500	1500	-	250kA/phase, 125kA/mode	420
PSP347S62/*#			✓	✓	✓	*	1500	1500	1500	-	300kA/phase, 150kA/mode	420

Note: “\* “ MCOV for L1-L 2

(end)