

PHOTOVOLTAIC (PV/ DC) SURGE PROTECTION MODULE PVTMOV...

Nowadays, Photovoltaic systems (PV System) range from small, rooftop-mounted or building-integrated systems with capacities from a few to several tens of kilowatts, to large utility-scale power stations of hundreds of megawatts, and in the meanwhile the potential impact of lightning events increases with PV system size. Where lightning occurrences are frequent, unprotected PV systems can suffer repeated and significant damage to key components. This results in substantial repair and replacement costs, system downtime and the loss of revenue.

PROSURGE has developed a high performance but low cost solution for the industry of PV/DC power electronics, a surge protection module **PVTMOV** which is size optimization and space efficiency, will be easy integrated on printed circuit boards (PCB) and close to sensitive electronic element inside device, to minimize the potential impact of lightning events.

PROSURGE® **PVTMOV** employ high energy Metal Oxide Varistor (MOV), and constructed with patented thermal protection and arc extinguishing technology which ensure safe disconnection while faulty current or abnormal voltage happened. It is generally known that the metal oxide varistor (MOV) is an ideal component for limiting surge voltage and current as well as for absorbing energy, but MOV may go into thermal runaway and result in short circuit due to sustained abnormal voltage (TOV) or end of life, that may cause fire hazard and significant losses to customer. Prosurge® surge protection modules have comprehensively improved the safety performance and proven to be excellent fail-safe and self-protected protective devices because of patented technology.

PVTMOV is PCB solderable module, especially for inverters, PV combiner boxes, converters application etc.



KEY BENEFIT

- TUV certified Class II/T 2 PV SPDs per IEC/EN 61643-31
- UL recognized Type 1ca surge protection modules per UL 1449 4th
- Completely meet IEC/EN 61643-11, EN50539-11 standards
- PCB mounting design and can be mounted close to the sensitive electronic element protected.
- Compatible with reflow and wave soldering procedure
- Compact size to save installation space
- High discharge capacity up to 25kA 8/20 due to heavy-duty metal oxide varistor (MOV)
- High reliability, fail-safe and self-protected, quick thermal response and perfect circuit cutoff function thanks to special thermal disconnecter design with arc extinguishing device (Patented).
- Wide operating temperature range (-40~+110°C)*
- Reliably at high altitudes location (-500m~+4000m qualified)
- Floating remote signaling contact for fault indication.

Note: Please point out while ordering, the temperature range of standard production is -40~80°C

PROTECTIVE CIRCUITS

The PROSURGE surge protection module must on all accounts be connected parallel to the electronic circuits to be protected.

There are three recommends protective circuits for PV/DC application while PROSURGE® PV/DC surge protection modules are used.

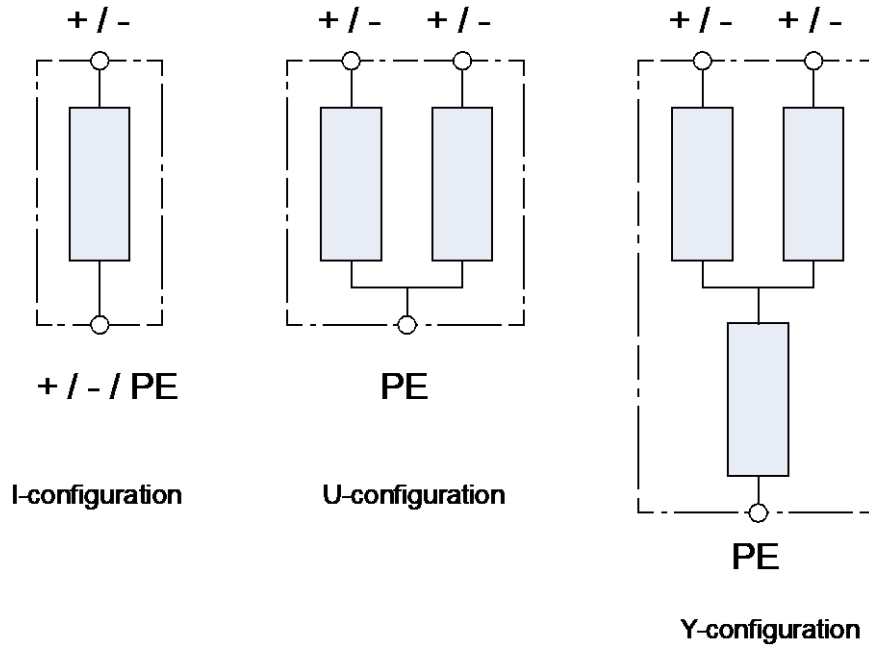

RECOMMENDED SOLDERING PROFILES

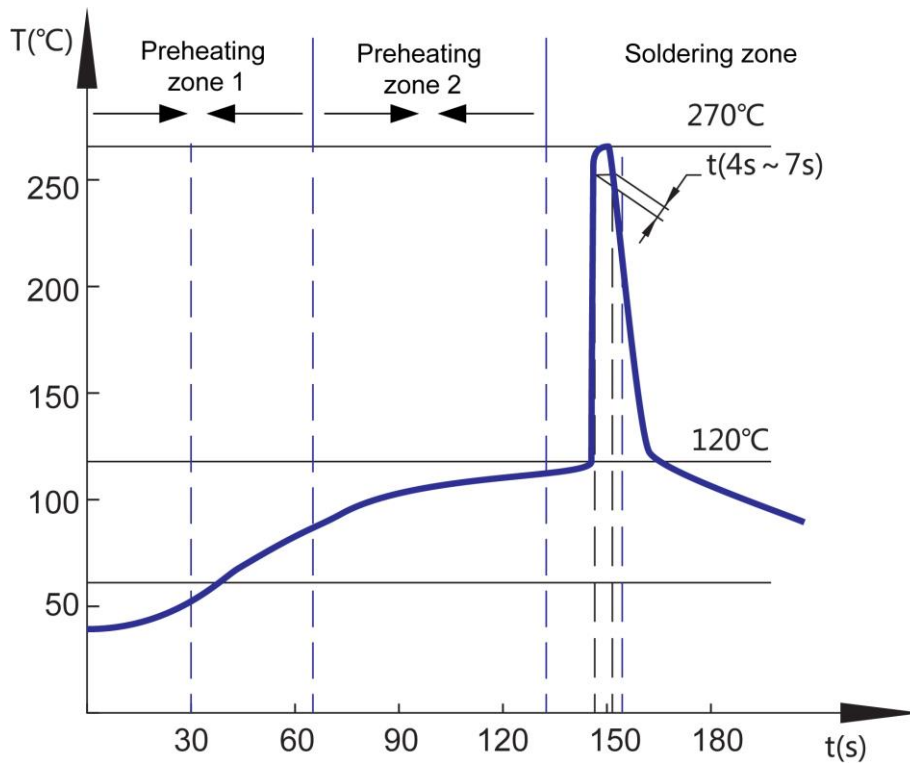

PVTMOV TECHNICAL DATA

Part No.		PVTMOVxxx/S									
		48	100	180	200	300	400	500	600	800	1000
Nominal voltage (Vdc)	Un	48	100	180	200	300	400	500	600	800	1000
Max. continuous operating DC voltage(Vdc)	Ucpv	48	100	180	200	300	400	500	600	800	1000
Nominal discharge current (8/20µs)	In	10kA									
Max. discharge current (8/20µs)	Imax	25kA									
Voltage protection rating level	Up	0.3kV	0.5kV	0.6kV	0.7kV	1.0kV	1.2kV	1.6kV	1.9kV	2.5kV	2.7kV
Continuous current for PV application	Icpv	<20uA									
Short circuit current rating		1000A									
Response time		≤25 ns									
Operating temperature range		Standard:-40°C ~ +80°C, extend: -40 °C ~+110 °C									
Humidity		≤95%									
Altitude		-500m~+4000m									
Enclosure material		thermoplastic; extinguishing degree UL94 V-0									
Insulation Resistance		≥20 M Ohm									
Remote alarm contact		Switching isolation Rating: 0.1A,12Vdc max									
Certification		TUV	TUV	TUV	TUV	TUV	TUV	TUV	TUV	TUV	TUV
Category, UL1449 4th		Type 1CA Type 2CA per CSA C22.2									
Category, IEC 61643-31/11		Class II									
Category ,EN50539-11; EN61643-31		Type 2									

MODEL SELECTION

PV System Voltage (Un)	Protective Circuit Used		
	I circuit	U circuit	Y circuit
48Vdc	PVTMOV48/S	2 x PVTMOV48/S	\
100Vdc	PVTMOV100/S	2 x PVTMOV100/S	\
200Vdc	PVTMOV200/S	2 x PVTMOV200/S	3 x PVTMOV100/S
300Vdc	PVTMOV300/S	2 x PVTMOV300/S	3 x PVTMOV180/S
400Vdc	PVTMOV400/S	2 x PVTMOV400/S	3 x PVTMOV200/S
500Vdc	PVTMOV500/S	2 x PVTMOV500/S	3 x PVTMOV300/S
600Vdc	PVTMOV600/S	2 x PVTMOV600/S	3 x PVTMOV300/S
800Vdc	PVTMOV800/S	2 x PVTMOV800/S	3 x PVTMOV400/S
1000Vdc	PVTMOV1000/S	2 x PVTMOV1000/S	3 x PVTMOV500/S
1200Vdc	\	\	3 x PVTMOV600/S
1500Vdc	\	\	3 x PVTMOV800/S

A. PVTMOV/PTMOV (Ucpv rating : 48~500Vdc)

DIMENSION DRAWING (mm)

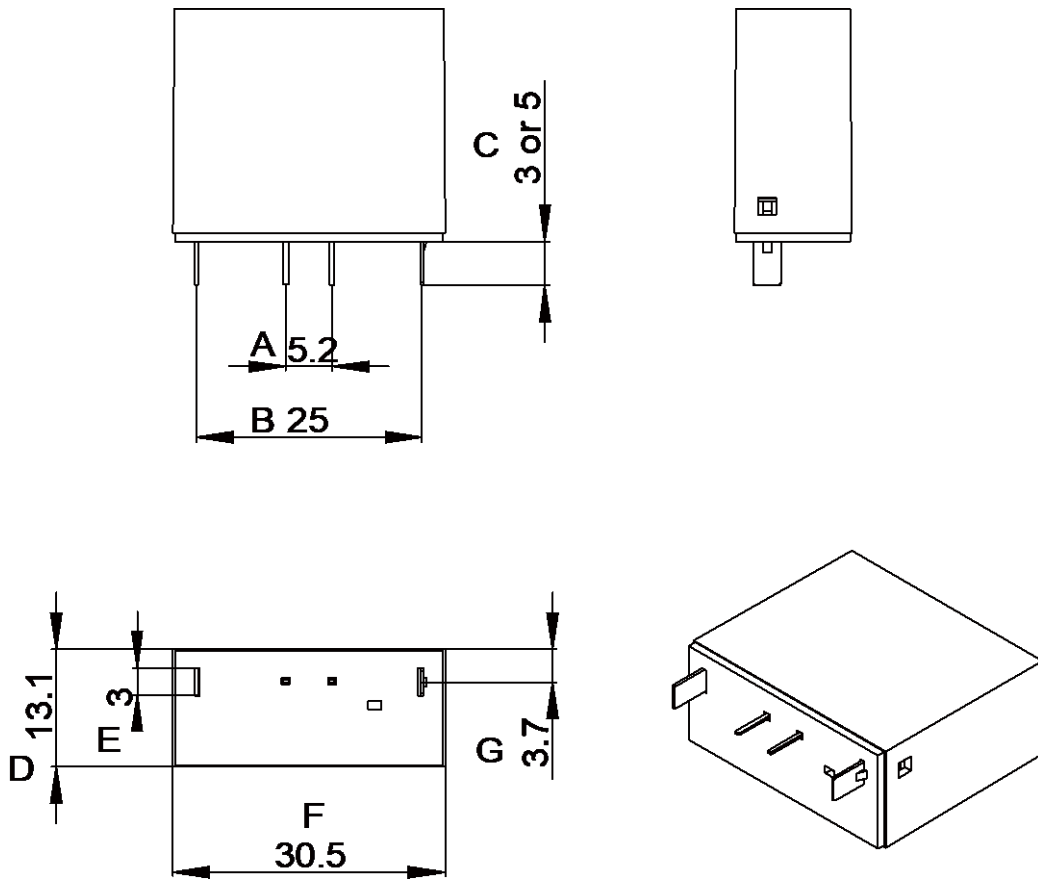

PCB LAYOUT DIMENSIONS: (mm)

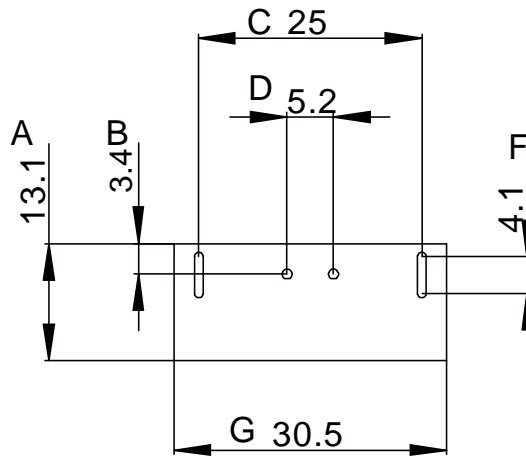

B. PVTMOV/PTMOV (Ucpv rating : 600~800Vdc)

DIMENSION DRAWING (mm)

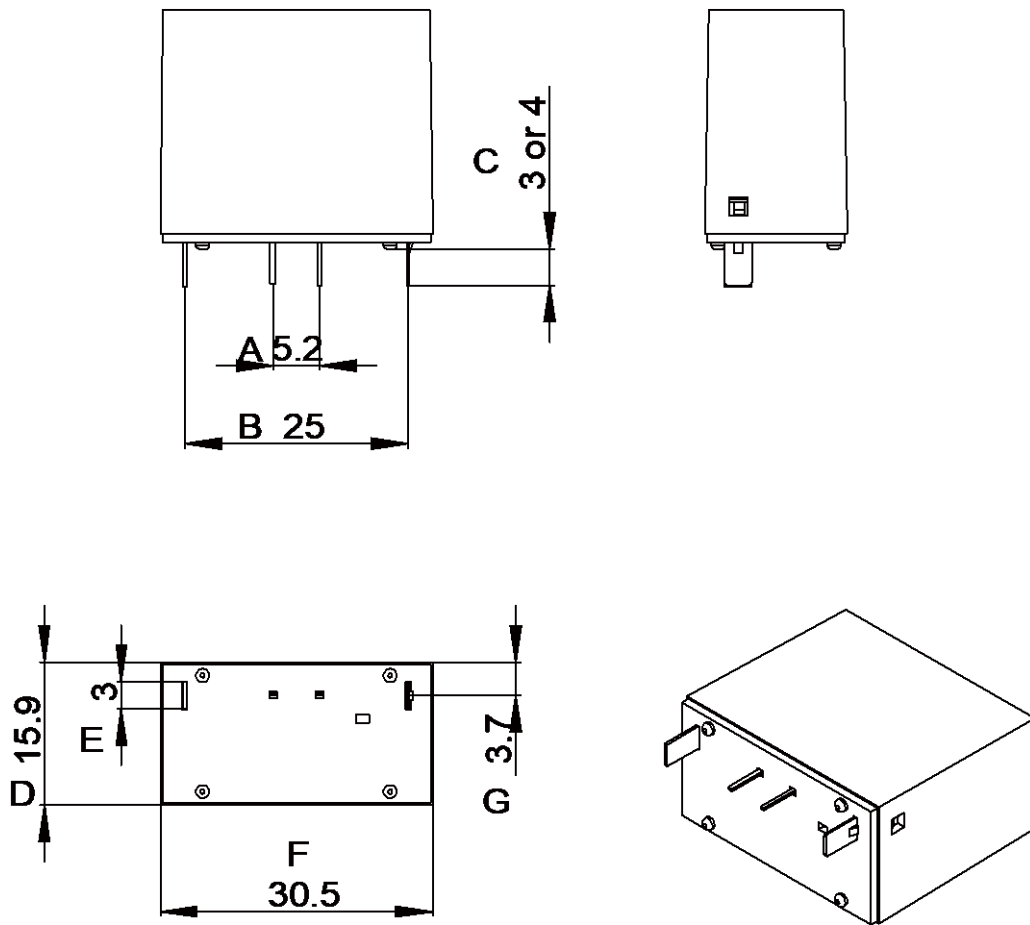

PCB LAYOUT DIMENSIONS: (mm)

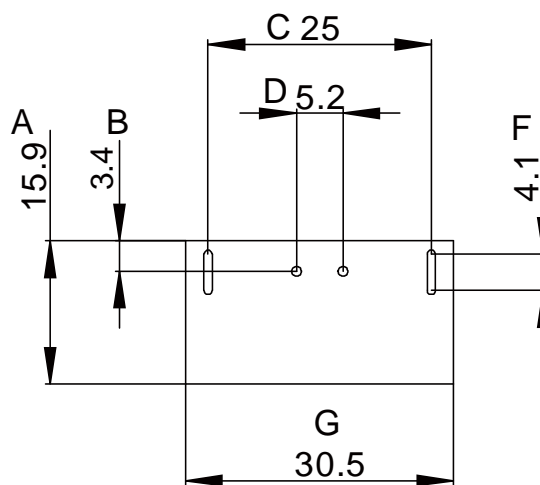

C. PVTMOV/PTMOV (Ucpv rating : 1000Vdc)

DIMENSION DRAWING (mm)

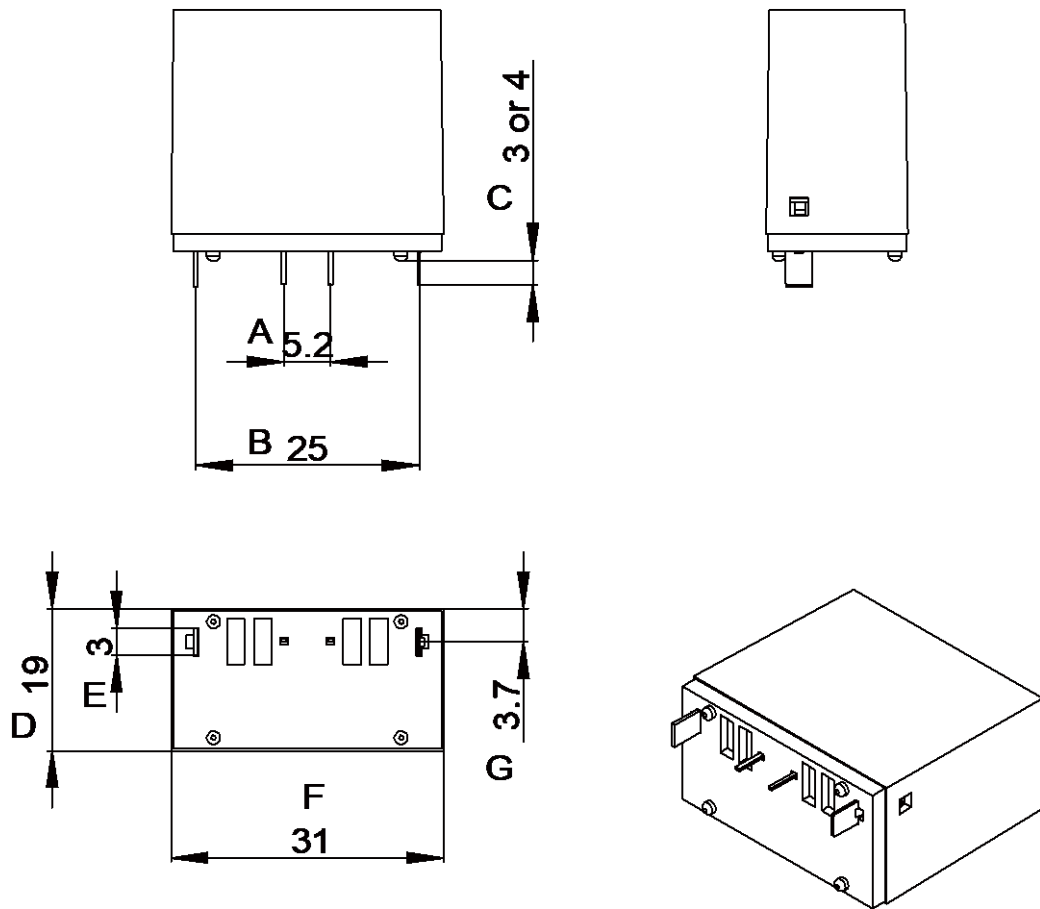

PCB LAYOUT DIMENSIONS: (mm)

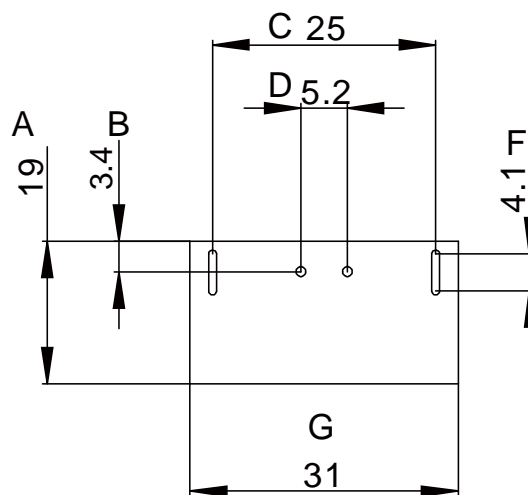

PTMOV TECHNICAL DATA

Part No.		PTMOVxxx/S									
		50	75	150	180	275	320	420	550	690	800
Nominal voltage (Vdc)	Un	48	100	180	200	300	400	500	600	800	1000
Max. continuous operating DC voltage(Vdc)	Ucpv	48	100	180	200	300	400	500	600	800	1000
Nominal discharge current (8/20µs)	In	10kA									
Max. discharge current (8/20µs)	Imax	25kA									
Voltage protection rating level	Up	0.3kV	0.5kV	0.6kV	0.7kV	1.0kV	1.2kV	1.6kV	1.9kV	2.5kV	2.7kV
Continuous current for PV application	Icpv	<20uA									
Short circuit current rating		1000A									
Response time		≤25 ns									
Operating temperature range		Standard:- 40°C ~ +80°C, extend: -40 °C ~+110 °C									
Humidity		≤95%									
Altitude		-500m~+4000m									
Enclosure material		thermoplastic; extinguishing degree UL94 V-0									
Insulation Resistance		≥20 M Ohm									
Remote alarm contact		Switching isolation Rating: 0.1A,12Vdc max									
Certification		TUV	TUV	TUV UL	TUV UL	TUV UL	TUV UL	TUV UL	TUV UL	TUV UL	TUV
Category, UL1449 4th		Type 1CA Type 2CA per CSA C22.2									
Category, IEC 61643-31/11		Class II									
Category ,EN50539-11; EN61643-31		Type 2									

MODEL SELECTION

PV System Voltage (Un)	Protective Circuit Used		
	I circuit	U circuit	Y circuit
48Vdc	PTMOV50/S	2 x PTMOV50/S	\
100Vdc	PTMOV75/S	2 x PTMOV75/S	\
200Vdc	PTMOV180/S	2 x PTMOV180/S	3 x PTMOV75/S
300Vdc	PTMOV275/S	2 x PTMOV275/S	3 x PTMOV150/S
400Vdc	PTMOV320/S	2 x PTMOV320/S	3 x PTMOV180/S
500Vdc	PTMOV420/S	2 x PTMOV420/S	3 x PTMOV275/S
600Vdc	PTMOV550/S	2 x PTMOV550/S	3 x PTMOV275/S
800Vdc	PTMOV690/S	2 x PTMOV690/S	3 x PTMOV320/S
1000Vdc	PTMOV800/S	2 x PTMOV800/S	3 x PTMOV420/S
1200Vdc	\	\	3 x PTMOV550/S
1500Vdc	\	\	3 x PTMOV690/S