

**POWER SUPPLY SYSTEM**

**Class I + Class II (T1+T2), PV DC Surge Arresters**

**PV50...-V**

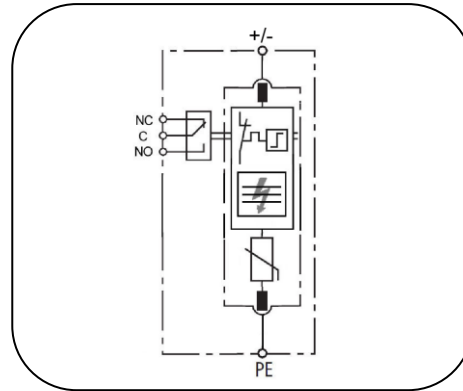

Basic circuit diagram

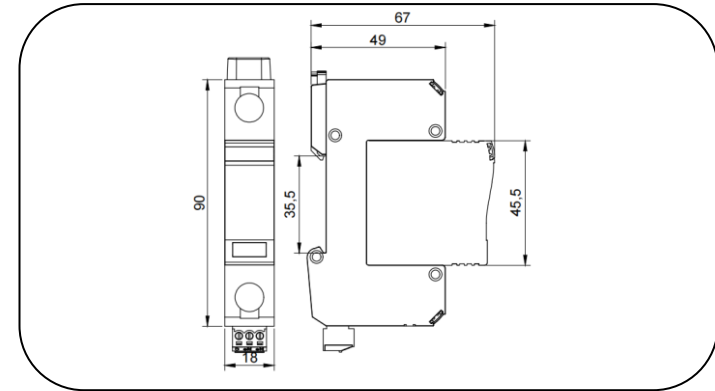

Dimension drawing

The PV50 V is class I & class II (or T1+T2) single pole PV DC SPD designed for DC application such as PV/ Photovoltaic system dc-side protection, especially for location of high risk exposure or LPZ 0-2 building entrances ( IEC 62305-4) to against the damage from direct or close lightning strikes.

With built in PROSURGE high energy MOV, PV50 V ensures remarkable lightning current discharge capacity up to 7.5kA 10/350µs and high reliability. The unique design of thermal protection provides quick thermal response and secure disconnection.

- TUV certified T1+ T2 PV DC SPD per IEC/EN 61643-31 standard.
- 18mm narrow model design, Single pole SPD for multi-purpose surge protection
- Application in Photovoltaic (PV) systems and other DC power system like charging system for electric vehicles etc.
- Unique thermal disconnecter design
- Lightning current capacity up to 7.5kA 10/350µs
- Surge current capability up to 50kA 8/20µs
- Low voltage protection level
- Degradation failure indication and optional remote signal contact.
- Pluggable module for easy replacement without the need to remove system wiring.
- Wide operating temperature -40° C ~85° C
- 35mm DIN-rail mounting
- Comply with EN 50539-11,UL1449 5<sup>th</sup>, IEEE C62.41,CSA C22.2 standards

**POWER SUPPLY SYSTEM**

**Technical data**

Part No.	PV50/48-V(-S)	PV50/75-V(-S)	PV50/100-V(-S)	PV50/150-V(-S)	PV50/200-V(-S)	PV50/300-V(-S)	PV50/400-V(-S)	PV50/500-V(-S)	PV50/600-V(-S)	PV50/750-V(-S)
In accordance with	IEC/EN 61643-31; UL1449 5 <sup>th</sup> ; EN 50539-11									
Category IEC/EU/VDE	I+ II /1+2/ B+C									
Protection mode	DC+ to DC- or DC+/- to PE									
Nominal Voltage (DC) $U_n$	48V	75V	100V	150V	200V	300V	400V	500V	600V	750V
Max. continuous operating voltage (DC) $U_{cpv}$	85V	100V	125V	170V	225V	350V	460V	560V	670V	800V
Nominal discharge current (8/20) $I_n$	20kA	20kA	20kA	20kA	20kA	20kA	20kA	20kA	20kA	20kA
Max. discharge current (8/20) $I_{max}$	50kA	50kA	50kA	50kA	50kA	50kA	50kA	50kA	50kA	50kA
Lightning impulse current (10/350) $I_{imp}$	7.5kA	7.5kA	7.5kA	7.5kA	7.5kA	7.5kA	7.5kA	6kA	4.5kA	4.5kA
Voltage protection level $U_p$	0.6kV	0.6kV	0.7kV	0.8kV	1.0kV	1.2kV	1.5kV	2.0kV	2.2kV	2.5kV
Response time $t_A$	≤25ns									
Leakage Current $I_{pe}$	<0.1mA									
Short-circuit Current $I_{scpv}$	1000A									
Operating temperature range	- 40°C ~ + 85°C									
Altitude	-500m ~ +4000m									
Cross-section of connection wire (max)	Single-strand 35mm <sup>2</sup> ; multi-strand 25mm <sup>2</sup>									
Mounting	35mm DIN-rail in accordance with EN 50022/DIN46277-3									
Enclosure material	thermoplastic; extinguishing degree UL94 V-0									
Degree of protection	IP20									
Installation width	1 module, DIN 43880									
Thermal disconnecter	Internal Green – normal ; red - failure									
Remote alarm contact	Optional									
Approvals, Certifications	TUV CE									
Additional data for Remote Alarm Contacts										
Remote alarm contact type	Isolated Form C									
Switching capability $U_n/I_n$	AC: 250V/0.5A DC: 250V/0.1A; 125V/0.2A; 75V/0.5A									
Cross-section of remote signaling wire	Max. 1.5mm <sup>2</sup> (or # 16AWG)									

**POWER SUPPLY SYSTEM**

**Class I + Class II (T1+T2), PV DC Surge Arresters**

**PV50...-V-C**

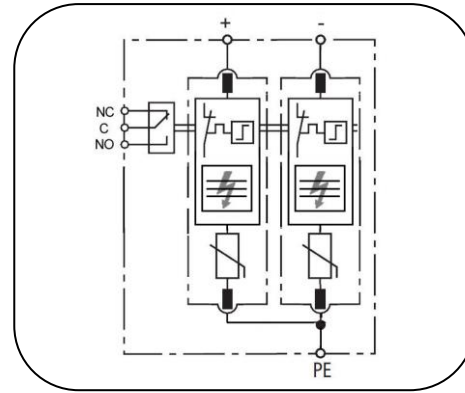

Basic circuit diagram

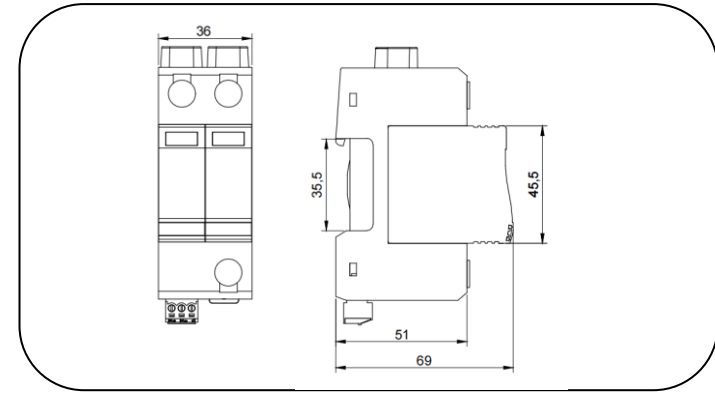

Dimension drawing

The PV50 C is class I & class II (or T1+T2 ) prewired PV DC SPD designed for DC application such as PV/ Photovoltaic system dc-side protection, especially for location of high risk exposure or LPZ 0-2 building entrances ( IEC 62305-4) to against the damage from direct or close lightning strikes.

With built in PROSURGE high energy MOV, PV50 C ensures remarkable lightning current discharge capacity up to 7.5kA 10/350µs and high reliability. The unique design of thermal protection provides quick thermal response and secure disconnection.

- TUV certified T1+ T2 PV DC SPD per IEC/EN 61643-31 standard.
- 18mm narrow model design, prewired two poles of V circuit for common mode protection
- Application in Photovoltaic (PV) systems and other DC power system like charging system for electric vehicles etc.
- Unique thermal disconnecter design
- Lightning current capacity up to 7.5kA 10/350µs
- Surge current capability up to 50kA 8/20µs
- Low voltage protection level
- Degradation failure indication and optional remote signal contact.
- Pluggable module for easy replacement without the need to remove system wiring.
- Wide operating temperature -40° C ~85° C
- 35mm DIN-rail mounting
- Comply with EN 50539-11,UL1449 5<sup>th</sup>, IEEE C62.41,CSA C22.2 standards

**POWER SUPPLY SYSTEM**

**Technical data**

Part No.	PV50/48-V-C (-S)	PV50/75-V-C(-S)	PV50/100-V-C(-S)	PV50/150-V-C(-S)	PV50/200-V-C(-S)	PV50/300-V-C(-S)	PV50/400-V-C(-S)	PV50/500-V-C(-S)	PV50/600-V-C(-S)	
In accordance with	IEC/EN 61643-31; UL1449 5 <sup>th</sup> ; EN 50539-11									
Category IEC/EU/VDE	I+ II /1+2/ B+C									
Protection mode	DC+ to DC- , DC+/- to PE									
Nominal Voltage (DC) Un	48V	75V	100V	150V	200V	300V	400V	500V	600V	
Max. continuous operating voltage (DC) Ucpv	85V	100V	125V	170V	225V	350V	460V	560V	670V	
Nominal discharge current (8/20) In	20kA	20kA	20kA	20kA	20kA	20kA	20kA	20kA	20kA	
Max. discharge current (8/20) Imax	50kA	50kA	50kA	50kA	50kA	50kA	50kA	50kA	50kA	
Lightning impulse current (10/350) Iimp	7.5kA	7.5kA	7.5kA	7.5kA	7.5kA	7.5kA	7.5kA	7.5kA	6kA	
Voltage protection level Up	DC+/- to PE	0.6kV	0.6kV	0.7kV	0.8kV	1.0kV	1.2kV	1.5kV	2.0kV	2.2kV
	DC + to DC -	1.0kV	1.0kV	1.2kV	1.5kV	2.0kV	2.2kV	2.8kV	3.5kV	4.0kV
Response time tA	≤25ns									
Leakage Current Ipe	<0.1mA									
Short-circuit Current Iscpv	1000A									
Operating temperature range	- 40°C ~ + 85°C									
Altitude	-500m ~ +4000m									
Cross-section of connection wire (max)	Single-strand 35mm <sup>2</sup> ; multi-strand 25mm <sup>2</sup>									
Mounting	35mm DIN-rail in accordance with EN 50022/DIN46277-3									
Enclosure material	thermoplastic; extinguishing degree UL94 V-0									
Degree of protection	IP20									
Installation width	2 modules, DIN 43880									
Thermal disconnecter	Internal Green – normal ; red - failure									
Remote alarm contact	Optional									
Approvals, Certifications	TUV, CE									
Additional data for Remote Alarm Contacts										
Remote alarm contact type	Isolated Form C									
Switching capability Un/In	AC: 250V/0.5A				DC: 250V/0.1A; 125V/0.2A; 75V/0.5A					
Cross-section of remote signaling wire	Max. 1.5mm <sup>2</sup> (or # 16AWG)									

## POWER SUPPLY SYSTEM

### Class I + Class II (T1+T2), PV DC Surge Arresters

#### PV50...-V-CD

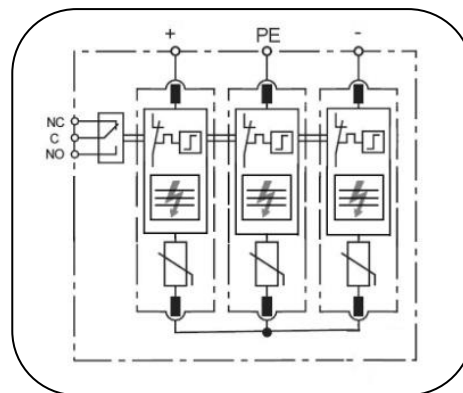

Basic circuit diagram

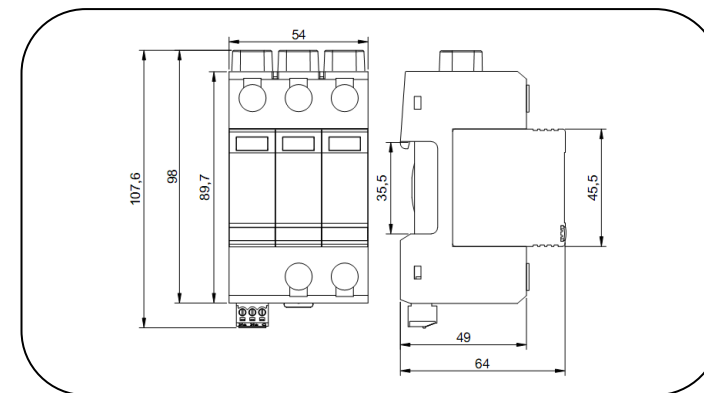

Dimension drawing

The PV50 CD is class I & class II (or T1+T2 ) prewired PV DC SPD designed for DC application such as PV/ Photovoltaic system dc-side protection, especially for location of high risk exposure or LPZ 0-2 building entrances ( IEC 62305-4) to against the damage from direct or close lightning strikes.

With built in PROSURGE high energy MOV, PV50 CD ensures remarkable lightning current discharge capacity up to 7.5kA 10/350 $\mu$ s and high reliability. The unique design of thermal protection provides quick thermal response and secure disconnection.

- TUV certified T1+ T2 PV DC SPD per IEC/EN 61643-31 standard.
- 18mm narrow model design, prewired three poles of Y circuit for common mode & differential mode protection
- Application in Photovoltaic (PV) systems and other DC power system like charging system for electric vehicles etc.
- Unique thermal disconnecter design
- Lightning current capacity up to 7.5kA 10/350 $\mu$ s
- Surge current capability up to 50kA 8/20 $\mu$ s
- Low voltage protection level
- Degradation failure indication and optional remote signal contact.
- Pluggable module for easy replacement without the need to remove system wiring.
- Wide operating temperature -40° C ~85° C
- 35mm DIN-rail mounting
- Comply with EN 50539-11,UL1449 5<sup>th</sup>, IEEE C62.41,CSA C22.2 standards

# POWER SUPPLY SYSTEM

## Technical data

Part No.	PV50/100-V-C D(-S)	PV50/200-V-C D(-S)	PV50/300-V-C D(-S)	PV50/400-V-C D(-S)	PV50/600-V-C (-S)	PV50/800-V-C D(-S)	PV50/1000-V-CD(-S)	PV50/1200-V-CD(-S)	PV50/1500-V-CD(-S)
In accordance with	IEC/EN 61643-31; UL1449 5 <sup>th</sup> ; EN 50539-11								
Category IEC/EU/VDE	I+ II /1+2/ B+C								
Protection mode	DC+ to DC- , DC+/- to PE								
Nominal Voltage (DC) $U_n$	100V	200V	300V	400V	600V	800V	1000V	1200V	1500V
Max. continuous operating voltage (DC) $U_{cpv}$	110V	250V	340V	450V	700V	920V	1120V	1340V	1500V
Nominal discharge current (8/20) $I_n$	20kA	20kA	20kA	20kA	20kA	20kA	20kA	20kA	20kA
Max. discharge current (8/20) $I_{max}$	50kA	50kA	50kA	50kA	50kA	50kA	50kA	50kA	50kA
Lightning impulse current (10/350) $I_{imp}$	7.5kA	7.5kA	7.5kA	7.5kA	7.5kA	7.5kA	6kA	4.5kA	4.5kA
Voltage protection level $U_p$ (DC+/- to PE, DC+ to DC-)	1.0kV	1.2kV	1.5kV	2.0kV	2.5kV	2.8kV	3.5kV	4.0kV	4.5kV
Response time $t_A$	$\leq 25ns$								
Leakage Current $I_{pe}$	$< 0.1mA$								
Short-circuit Current $I_{scpv}$	1000A								
Operating temperature range	$- 40^{\circ}C \sim + 85^{\circ}C$								
Altitude	$-500m \sim +4000m$								
Cross-section of connection wire (max)	Single-strand 35mm <sup>2</sup> ; multi-strand 25mm <sup>2</sup>								
Mounting	35mm DIN-rail in accordance with EN 50022/DIN46277-3								
Enclosure material	thermoplastic; extinguishing degree UL94 V-0								
Degree of protection	IP20								
Installation width	3 modules, DIN 43880								
Thermal disconnecter	Internal Green – normal ; red - failure								
Remote alarm contact	Optional								
Approvals, Certifications	TUV, CE								
Additional data for Remote Alarm Contacts									
Remote alarm contact type	Isolated Form C								
Switching capability $U_n/I_n$	AC: 250V/0.5A				DC: 250V/0.1A; 125V/0.2A; 75V/0.5A				
Cross-section of remote signaling wire	Max. 1.5mm <sup>2</sup> (or # 16AWG)								

**POWER SUPPLY SYSTEM**

**Plug-In module**

**MPV...-V**

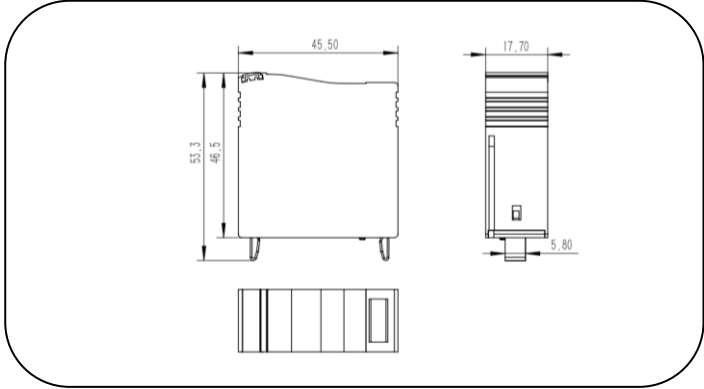

Dimension drawing of MPV module

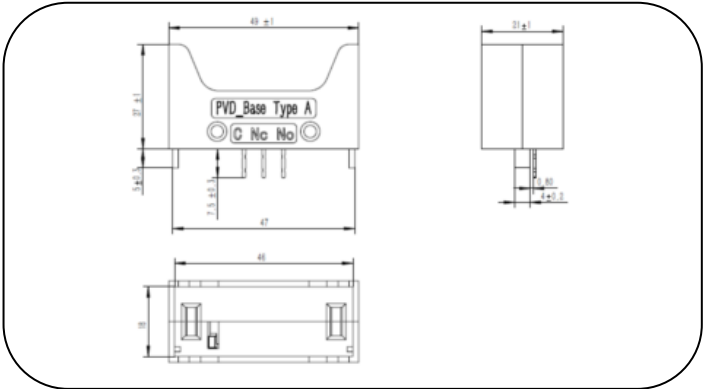

Dimension drawing of PVD\_Base

Class I & Class II (or T1 + T2) plug-in module for PV50 series replacement, which is heavy MOV based device with Prosurge's thermal protection and arc extinguishing technology. MPV module can be easily integrated on printed circuit boards (PCB) and installed closest to sensitive electronic element inside PV/ DC power electronics while used together with PVD base, it will help to protect the most important circuit and minimize the potential impact of lightning events. Further, optimal voltage protection level is achieved for the electronics of the PCB since there is no cable length between the SPD and the device to be protected. The PVD\_Base also helps to provide floating remote signal for module fault indication.



MPV module with PVD\_Base

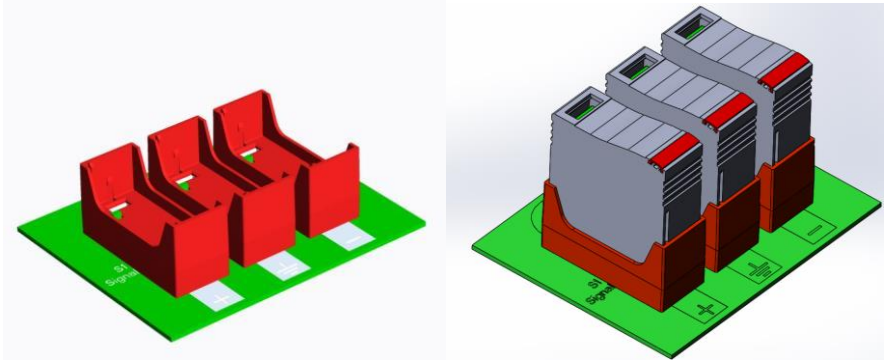

PVD\_Base can be soldered on PCBs directly

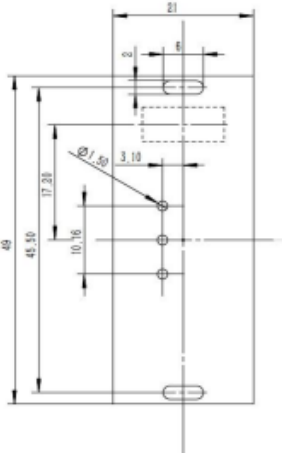

PCB layout dimensions of PVD\_Base

**POWER SUPPLY SYSTEM**

**Technical data**

Part No.	MPV50/48-V	MPV50/75-V	MPV50/100-V	MPV50/150-V	MPV50/200-V	MPV50/300-V	MPV50/400-V	MPV50/500-V	MPV50/600-V	MPV50/750-V
In accordance with	IEC/EN 61643-31; UL1449 5 <sup>th</sup> ; EN 50539-11									
Category IEC/EU/VDE	I+ II /1+2/ B+C									
Nominal Voltage (DC) $U_n$	48V	75V	100V	150V	200V	300V	400V	500V	600V	750V
Max. continuous operating voltage (DC) $U_{cpv}$	85V	100V	125V	170V	225V	350V	460V	560V	670V	800V
Nominal discharge current (8/20) $I_n$	20kA	20kA	20kA	20kA	20kA	20kA	20kA	20kA	20kA	20kA
Max. discharge current (8/20) $I_{max}$	50kA	50kA	50kA	50kA	50kA	50kA	50kA	50kA	50kA	50kA
Lightning impulse current (10/350) $I_{imp}$	7.5kA	7.5kA	7.5kA	7.5kA	7.5kA	7.5kA	7.5kA	6kA	4.5kA	4.5kA
Voltage protection level $U_p$	0.6kV	0.6kV	0.7kV	0.8kV	1.0kV	1.2kV	1.5kV	2.0kV	2.2kV	2.5kV
Leakage Current $I_{pe}$	<0.1mA									
Short-circuit Current $I_{scpv}$	1000A									
Operating temperature range	- 40°C ~ + 85°C									
Enclosure material	thermoplastic; extinguishing degree UL94 V-0									
Degree of protection	IP20									
Thermal disconnecter	Internal Green – normal ; red - failure									
Approvals, Certifications	TUV, CE									
Additional data for PVD_Base's remote alarm contacts										
Remote alarm contact type	Isolated Form C									
Switching capability $U_n/I_n$					AC: 250V/0.5A	DC: 250V/0.1A; 125V/0.2A; 75V/0.5A				